

***С*НАМПИОН®**

**ДЕТАЛИРОВКА
СНЕГОУБОРЩИКА
ST969BS**

PRODUCT COMPONENTS	PAGES
Handles Group	4
Engine & Frame Group	6
Auger Drive Group	10
Auger Housing Group	12
Traction Drive Group	14
Wheel & Tire Group	16
Decals Group	18
Headlight Group	20
Discharge Chute Group	22
Gear Case Assembly	26
Controls Group	28
Torque Specification Chart	Inside Back Cover

Handles Group

NOTE: Unless noted otherwise,
use the standard hardware torque
specification chart.

:\alog_Data\MUR\Images\groups\2980000\2989377a

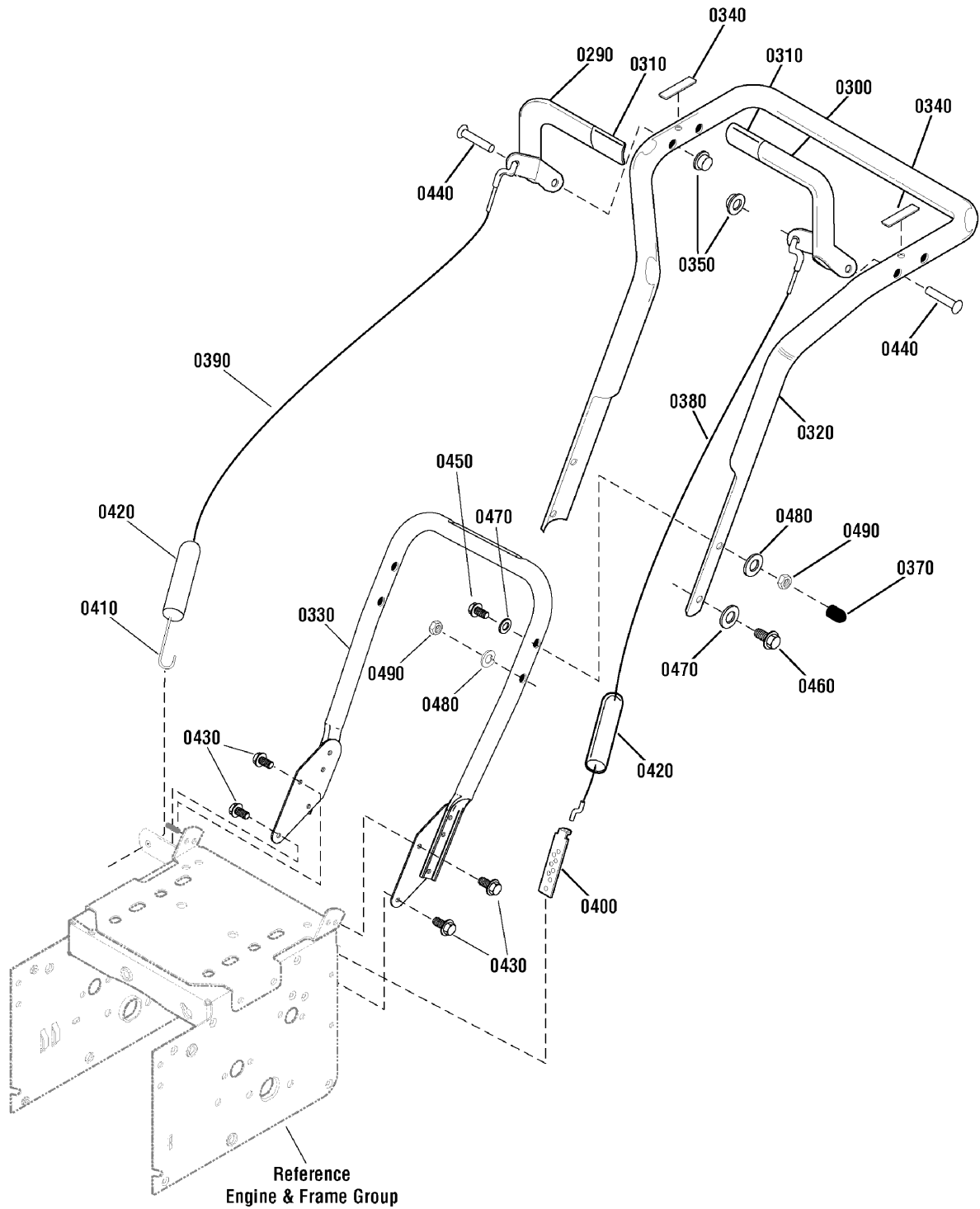

The above parts group applies to the following Mfg. Nos.:

- 1695952 - Champion 11.5TP 27" Dual Stage Snowthrower
- 1695953 - Champion 14.5TP 30" Dual Stage Snowthrower

Handles Group

REF NO	PART NO.	QTY.	DESCRIPTION
0290	5146E701MA	1	LEVER ASSEMBLY, RH
0300	5142E701MA	1	LEVER ASSEMBLY, LH
0310	333928MA	2	GRIP, Control Lever
0320	1741120AYP	1	HANDLE, Upper
0330	1740580AYP	1	HANDLE, Lower
0340	4049MA	2	BUMPER
0350	3535MA	2	NUT, Push Cap, 5/16
0370	7289MA	3	STOP
0380	1502113MA	1	CABLE, Front Drive
0390	761872MA	1	CABLE, Auger
0400	313441MA	1	BRACKET, Cable Adjusting
0410	1673MA	1	SPRING, Auger Control
0420	308146MA	1	BOOT, Spring End Cover
0430	25X021MA	4	CAPSCREW, Hex Washer Head, 5/16-18 x 3/4
0440	760074MA	2	PIN, Pivot Control
0450	7288MA	2	CAPSCREW, Hex Head, 3/8-16 x 3
0460	71007MA	1	CAPSCREW, Hex Head, 3/8-16 x 2
0470	71072MA	3	WASHER, Flat, 1/2
0480	71062MA	3	WASHER, 3/8
0490	71044MA	3	NUT, Hex, 3/8-16

Footnotes

The above parts group applies to the following Mfg. Nos.:

1695952 - Champion 11.5TP 27" Dual Stage Snowthrower

1695953 - Champion 14.5TP 30" Dual Stage Snowthrower

Engine & Frame Group

NOTE: Unless noted otherwise, use the standard hardware torque specification chart.

atalog_Data\MUR\Images\groups\2980000\2989375

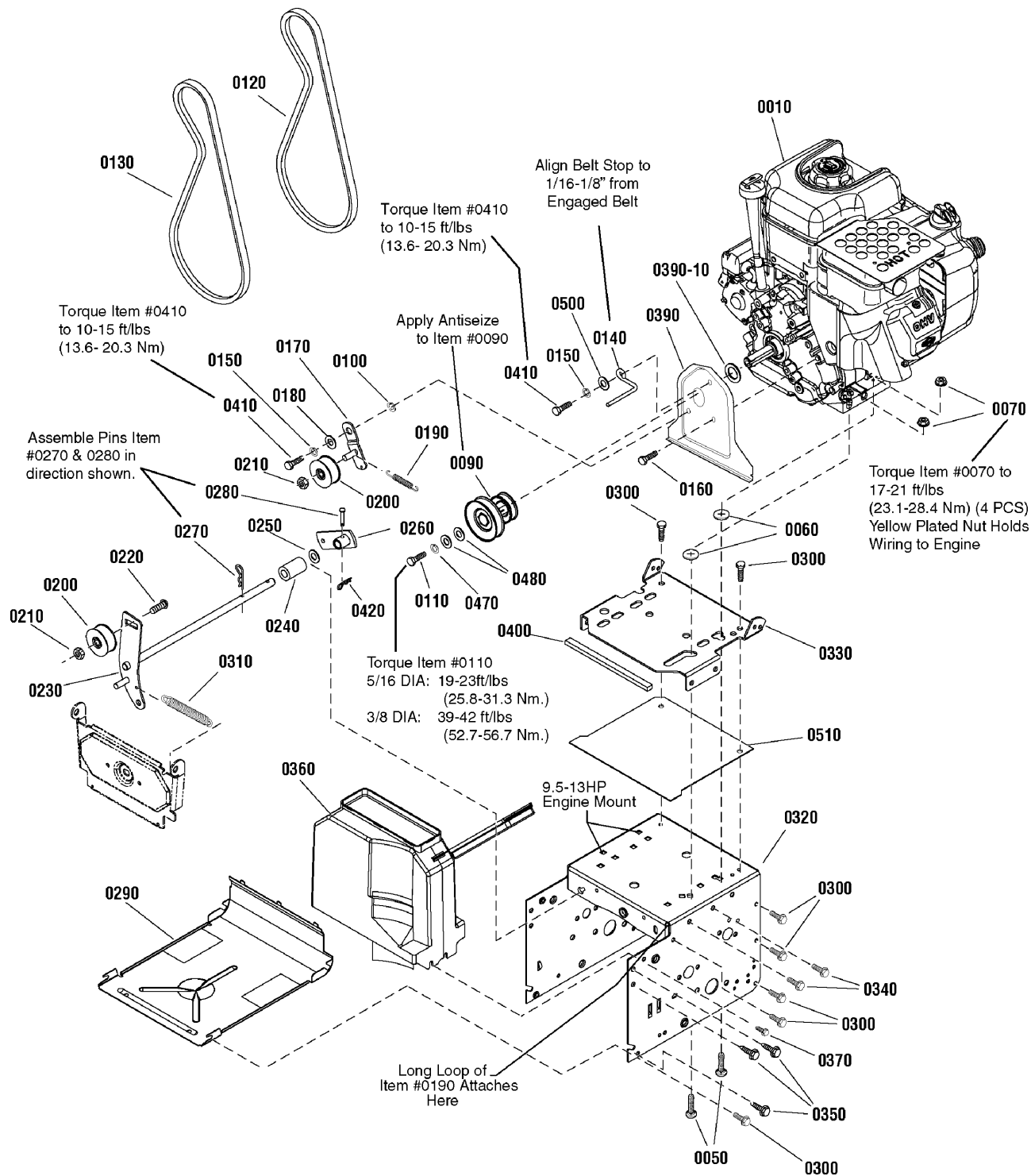

The above parts group applies to the following Mfg. Nos.:

- 1695952 - Champion 11.5TP 27" Dual Stage Snowthrower
- 1695953 - Champion 14.5TP 30" Dual Stage Snowthrower

Engine & Frame Group

REF NO	PART NO.	QTY.	DESCRIPTION
0010	15C114-0121-E8	1	* ENGINE, 11.5 TP Briggs & Stratton (Engine Model 15C114-0121-E8)
0010	20M314-0115-E1	1	* ENGINE, 14.5 TP Briggs & Stratton (Engine Model 20M314-0115-E1)
0050	002X97MA	4	BOLT, Carriage, 5/16-18 x 1-1/2
0060	028X76MA	4	PUSHNUT, 1/4
0070	1739305YP	4	NUT, Hex Flange, ESNA, 5/16-18
0090	1501109MA	1	PULLEY, Engine
0100	1919381SM	3	WASHER, 5/16
0110	1921982SM	1	CAPSCREW, Hex Head, 5/16-24 x 1-1/4, G5 (Use on 11.5TP models)
0110	1960428SM	1	CAPSCREW, Hex Head, 3/8-24 x 1-1/4 (Use on 14.5TP models)
0120	1733324SM	1	V-BELT, Traction Drive, 3L 33.13
0130	585416MA	1	BELT, Auger Drive, V4L 38.10
0140	1739070YP	1	BELT GUIDE
0150	1917356SM	4	LOCKWASHER, Spring, 5/16
0160	1921515SM	1	CAPSCREW, Hex Head, 5/16-24 x 3/4 G5
0170	1501112YZMA	1	IDLER BRACKET
0180	1501065MA	1	BUSHING, Idler Bracket
0190	53704MA	1	SPRING, Extension, Idler
0200	1502120MA	2	IDLER
0210	1960251SM	2	NUT, Hex Centerlock Jam, 3/8-16
0220	585781MA	1	BOLT, Carriage, Short Neck, 3/8-16 x 1-1/4, G5
0230	1501226YZMA	1	IDLER ASSEMBLY, Auger
0240	1501200MA	1	SPACER, 1/2 ID x 1OD x 1-3/4"
0250	1960027SM	1	WASHER, 1/2
0260	1733451SM	1	ARM, Control
0270	0031X6MA	1	PIN, Hair
0280	1736381YP	1	PIN, Clevis
0290	1740906ASM	1	PANEL, Bottom
0300	1927429SM	12	SCREW, Hex Washer Head, Taptite, 1/4-20 x 5/8
0310	165X159MA	1	SPRING, Extension, Auger
0320	1740572ZMA	1	FRAME BOX (Use on 11.5TP models)
0320	1740571ZMA	1	FRAME BOX (Use on 14.5TP models)
0330	1733583ZYP	1	PLATE, Engine Mount
0340	25X020MA	4	CAPSCREW, Hex Washer Head, 5/16-18 x 1/2
0350	1664847SM	6	SCREW, Hex Washer Head, Taptite, 5/16-18 x 3/4
0360	1733923SM	1	BELT COVER ASSEMBLYa
0370	26X306MA	2	SCREW, Hex Washer Head, Tapping, SEMS, 1/4 x 3/4
0390	1733868ASM	1	PLATE, Seal
0390-10	1733898SM	1	SEAL, Foam (Use on 11.5TP models)
0390-10	1750185YP	1	SEAL, Foam (Use on 14.5TP models)
0400	1750172YP	1	STRIP, Seal
0410	910828MA	2	BOLT, Hex, 5/16-24 x 1
0420	7023590SM	1	COTTER PIN, Self Lock, 1/4
0470	1917356SM	1	LOCKWASHER, Spring, 5/16 (Use on 11.5TP models)

Footnotes

Note* See your local Briggs & Stratton distributor for parts and service.

The above parts group applies to the following Mfg. Nos.:

1695952 - Champion 11.5TP 27" Dual Stage Snowthrower
 1695953 - Champion 14.5TP 30" Dual Stage Snowthrower

Engine & Frame Group

NOTE: Unless noted otherwise, use the standard hardware torque specification chart.

atalog_Data\MUR\Images\groups\2980000\2989375

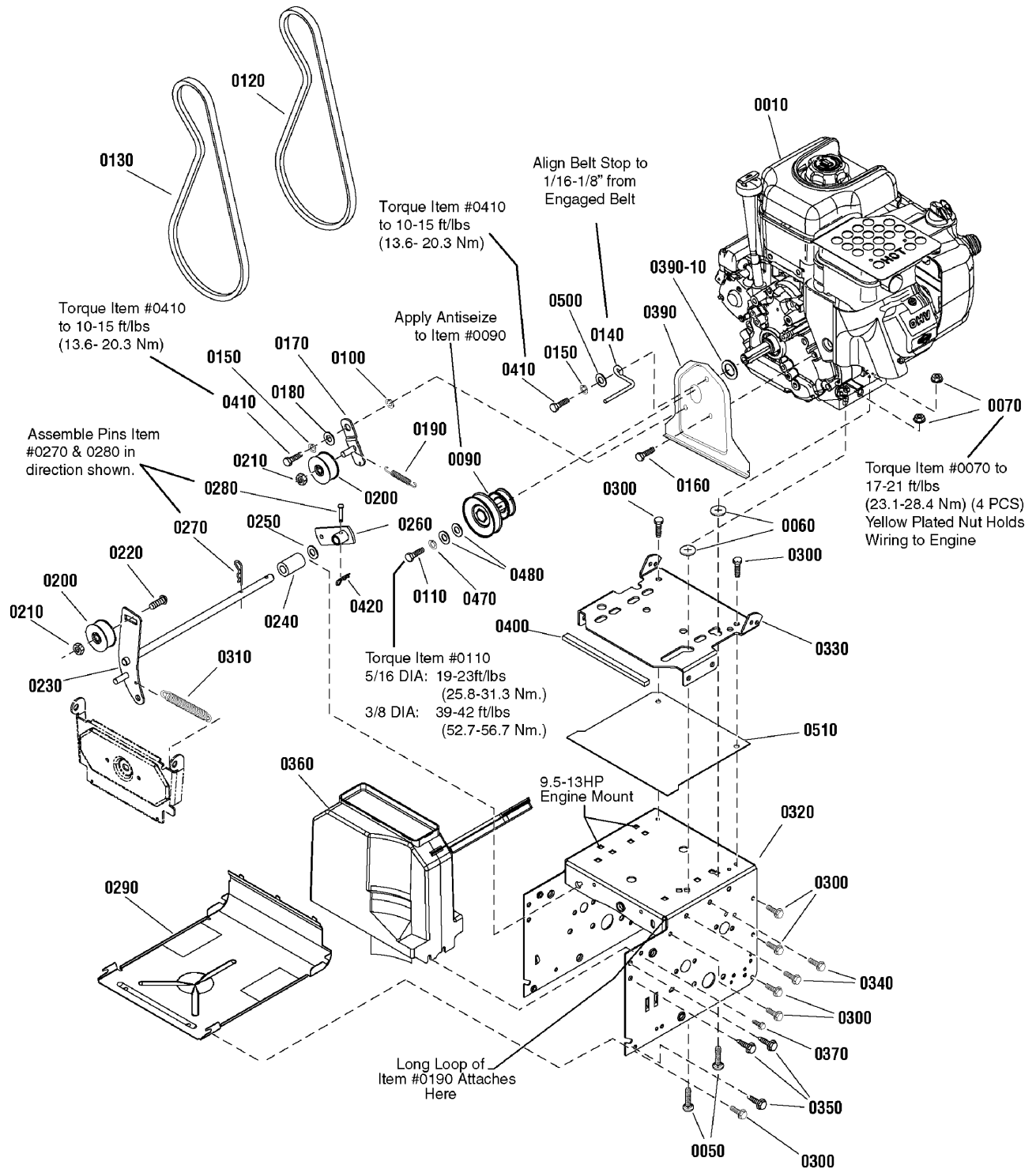

The above parts group applies to the following Mfg. Nos.:

- 1695952 - Champion 11.5TP 27" Dual Stage Snowthrower
- 1695953 - Champion 14.5TP 30" Dual Stage Snowthrower

Engine & Frame Group

REF NO	PART NO.	QTY.	DESCRIPTION
0470	1916965SM	1	LOCKWASHER, Spring (Use on 14.5TP models)
0480	1919381SM	2	WASHER, 5/16 (Use on 11.5TP models)
0480	1922755SM	2	WASHER, 3/8 (Use on 14.5TP models)
0500	7091528SM	1	WASHER, Flat, 3/8
0510	1750135YP	1	SEAL, Engine Plate

Footnotes

Note* See your local Briggs & Stratton distributor for parts and service.

The above parts group applies to the following Mfg. Nos.:

1695952 - Champion 11.5TP 27" Dual Stage Snowthrower
1695953 - Champion 14.5TP 30" Dual Stage Snowthrower

Auger Drive Group

NOTE: Unless noted otherwise,
use the standard hardware torque
specification chart.

atalog_Data\MUR\Images\groups\2980000\2988418

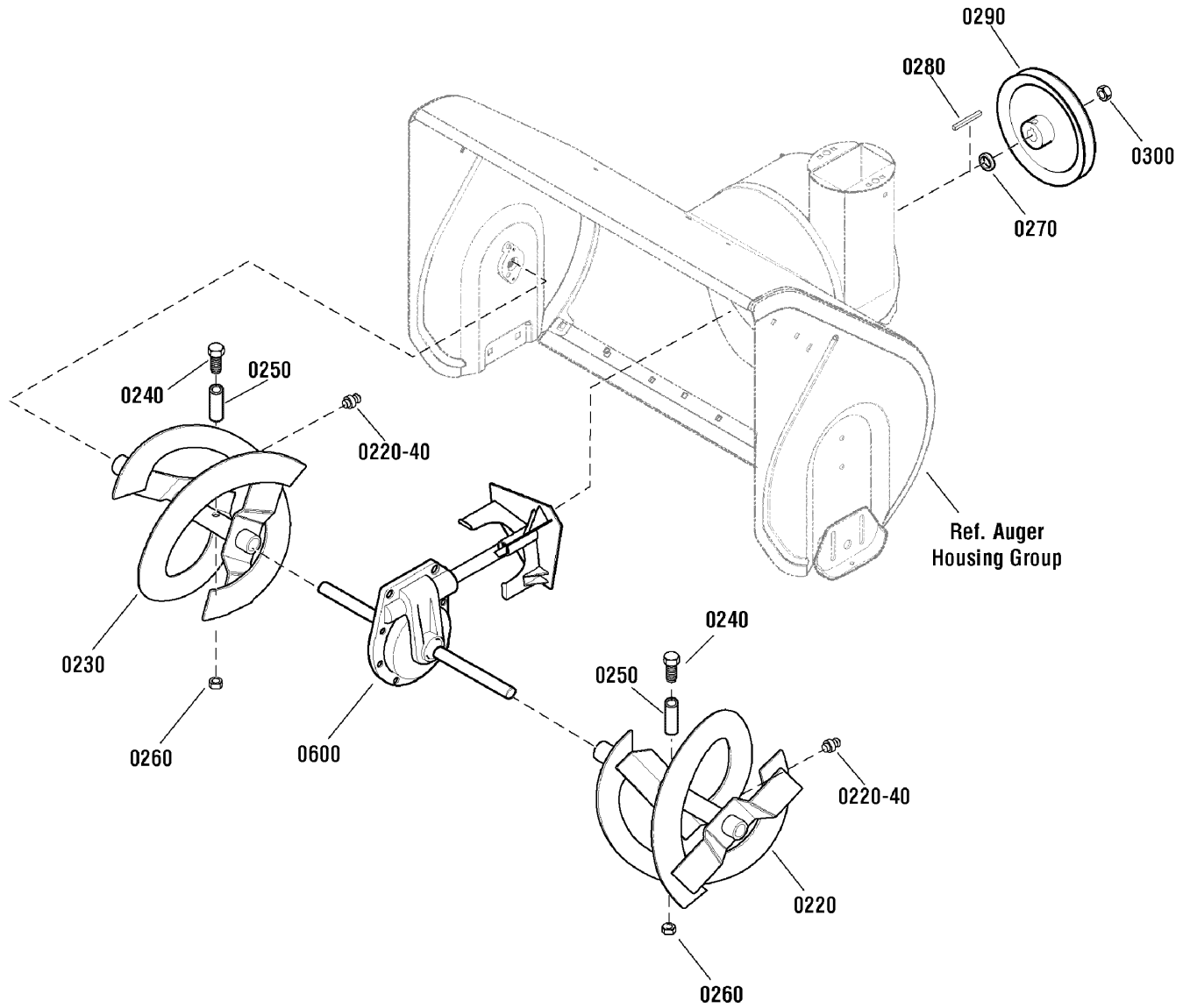

The above parts group applies to the following Mfg. Nos.:

1695952 - Champion 11.5TP 27" Dual Stage Snowthrower

1695953 - Champion 14.5TP 30" Dual Stage Snowthrower

Auger Drive Group

REF NO	PART NO.	QTY.	DESCRIPTION
0220	1738044BCYP	1	AUGER, 27", LH (Includes Ref. No. 0220-40)
0220	1738042BCYP	1	AUGER, 30", LH (Includes Ref. No. 0220-40)
0230	1738043BCYP	1	AUGER, 27", RH (Includes Ref. No. 0220-40)
0230	1738041BCYP	1	AUGER, 30", RH (Includes Ref. No. 0220-40)
0220-40	10104MA	2	FITTING, Grease
0240	9524MA	2	CAPSCREW, Hex Head, 1/4-20 x 1-3/4
0250	3943MA	2	SPACER, Sleeve, 1/4 x 1/2
0260	73826MA	2	NUT, Hex Centerlock, 1/4-20
0270	1501158MA	1	SPACER, Friction Pulley
0280	2001022MA	1	KEY, Square, 3/16 x 3/4
0290	583146MA	1	PULLEY
0300	15X112MA	1	NUT, Hex Flange Serrated, 1/2-20
0600	1738603YP	1	GEAR CASE ASSEMBLY, 27 (Use on 27" Models)
0600	1738606YP	1	GEAR CASE ASSEMBLY, 30 (Use on 30" Models)
--	1501216MA	1	SHEAR BOLT KIT (Includes Ref. Nos. 0240, 0250 & 0260)

Footnotes

The above parts group applies to the following Mfg. Nos.:

1695952 - Champion 11.5TP 27" Dual Stage Snowthrower
1695953 - Champion 14.5TP 30" Dual Stage Snowthrower

Auger Housing Group

NOTE: Unless noted otherwise,
use the standard hardware torque
specification chart.

atalog_Data\MUR\Images\groups\2980000\2989378

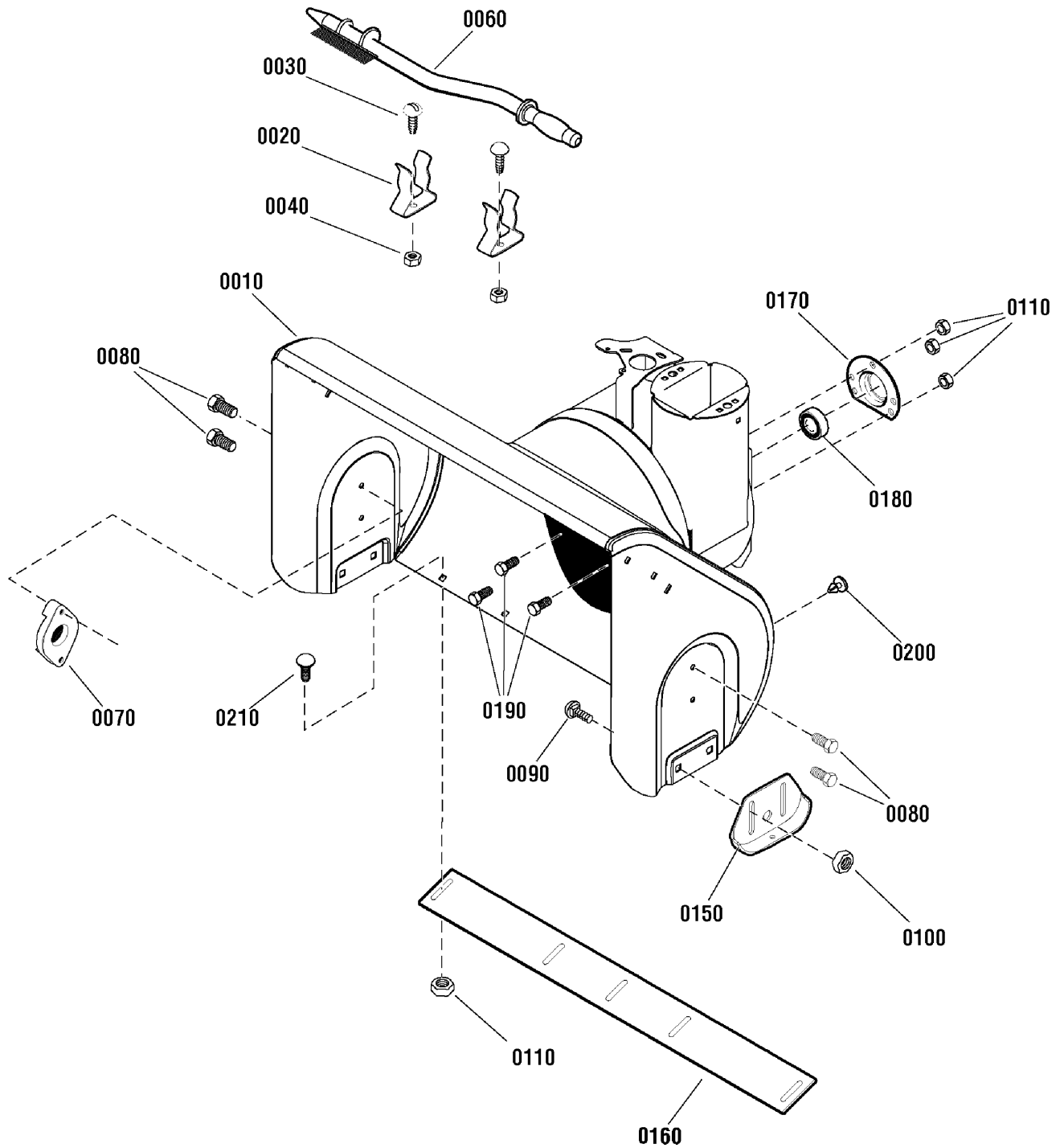

The above parts group applies to the following Mfg. Nos.:

1695952 - Champion 11.5TP 27" Dual Stage Snowthrower

1695953 - Champion 14.5TP 30" Dual Stage Snowthrower

Auger Housing Group

REF NO	PART NO.	QTY.	DESCRIPTION
0010	1737905ZYP	1	AUGER HOUSING, 27"
0010	1737903ZYP	1	AUGER HOUSING, 30"
0020	1736620YP	2	CLAMP
0030	1960569SM	2	SCREW, Truss Head Torx, #10-24 x 3/8
0040	7091290SM	2	NUT, Hex Lock, Nylon, #10C
0060	1736094YP	1	BRUSH, Cleanout
0070	53757MA	2	BEARING, Auger
0080	25X021MA	4	CAPSCREW, Hex Washer Head, 5/16-18 x 3/4
0090	7091547YP	4	BOLT, Carriage, Short Neck, 3/8-16 x 3/4, G5
0100	7091619SM	4	NUT, Hex Flange Lock, 3/8-16
0110	710026MA	7	NUT, Hex Flange, Serrated, 5/16-18
0150	1740912AYP	2	SKID, Height Adjust, S4 (Use on 27" Housing)
0150	1737985AYP	1	SKID, Height Adjust, S5 (Use on 30" Housing)
0160	1740949AYP	1	BLADE, Scraper, 27"
0160	1738333AYP	1	BLADE, Scraper, 30"
0170	582957YZMA	1	RETAINER, Ball Bearing
0180	1705897SM	1	BEARING, Ball
0190	001X45MA	3	BOLT, Hex, 5/16-18 x 5/8
0200	760040MA	2	PLUG, Panel
0210	7090799SM	4	BOLT, Carriage, Short Neck, 5/16-18 x 5/8, G5

Footnotes

The above parts group applies to the following Mfg. Nos.:

1695952 - Champion 11.5TP 27" Dual Stage Snowthrower

1695953 - Champion 14.5TP 30" Dual Stage Snowthrower

Traction Drive Group

NOTE: Unless noted otherwise,
use the standard hardware torque
specification chart.

\\Catalog_Data\MUR\Images\2009\1695696\2988389

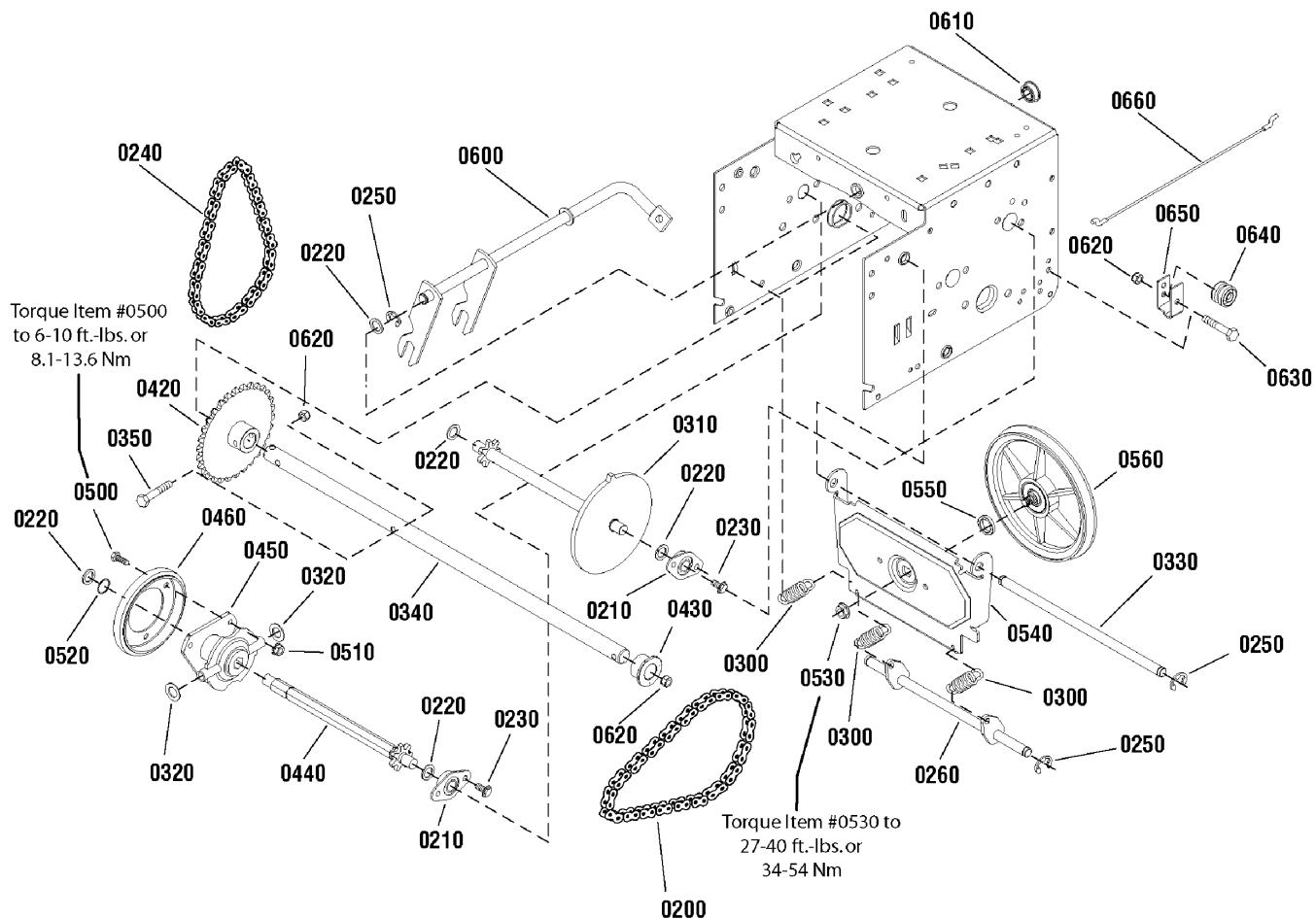

The above parts group applies to the following Mfg. Nos.:

1695952 - Champion 11.5TP 27" Dual Stage Snowthrower

1695953 - Champion 14.5TP 30" Dual Stage Snowthrower

Traction Drive Group

REF NO	PART NO.	QTY.	DESCRIPTION
0200	579851MA	1	CHAIN, Roller
0210	334163MA	4	RETAINER & BUSHING ASSEMBLY
0220	579858MA	5	WASHER
0230	1924856SM	8	SCREW, Hex Washer Head, Taptite, 5/16-18 x 1/2
0240	579868MA	1	CHAIN, Roller
0250	11X30MA	5	RETAINER, Ring, 7/16
0260	1502105YZMA	1	SPRING LINK ASSEMBLY
0300	1736469YP	3	SPRING, Extension
0310	1501090MA	1	SPROCKET, Set
0320	1960027SM	2	WASHER, 1/2
0330	1501092YZMA	1	AXLE, Swing Plate
0340	1501563MA	1	AXLE, Bushing
0350	01X193MA	1	CAPSCREW, Hex, 1/4-20 x 1-3/4, G8
0420	1501089MA	1	SPROCKET, Axle
0430	1501114MA	2	BEARING, Axle D-Hole
0440	1501100MA	1	HEX SHAFT & SPROCKET ASSEMBLY
0450	337029MA	1	HUB, Friction Wheel & Bearing
0460	1501435MA	1	WHEEL, Friction
0500	1921959SM	3	CAPSCREW, Hex Head 1/4-20 x 5/8, G5
0510	1928372SM	3	NUT, Hex, KEPS, 1/4-20
0520	1733326SM	1	RING, Retaining Extension
0530	15X114MA	1	NUT, Flange Lock, 3/8-24
0540	1501057YZMA	1	PLATE, Swinging
0550	1501158MA	1	SPACER, Friction Pulley
0560	1501115MA	1	FRICTION PULLEY ASSEMBLY
0600	1501110YZMA	1	SPEED SELECTOR ASSEMBLY
0610	579944MA	1	BEARING, Flange
0620	1920397SM	2	NUT, Hex Lock, ESNA Light, 1/4-20
0630	1922837SM	1	CAPSCREW, Hex Head, 1/4-20 x 1-1/2, G5
0640	579860MA	1	SPOOL CABLE, Auger Control
0650	1501059YZMA	1	BRACKET, Cable Spool
0660	1501122MA	1	CABLE, Front Drive Lower

Footnotes

The above parts group applies to the following Mfg. Nos.:

1695952 - Champion 11.5TP 27" Dual Stage Snowthrower

1695953 - Champion 14.5TP 30" Dual Stage Snowthrower

Wheel & Tire Group

NOTE: Unless noted otherwise,
use the standard hardware torque
specification chart.

atalog_Data\MUR\Images\groups\2980000\2989411

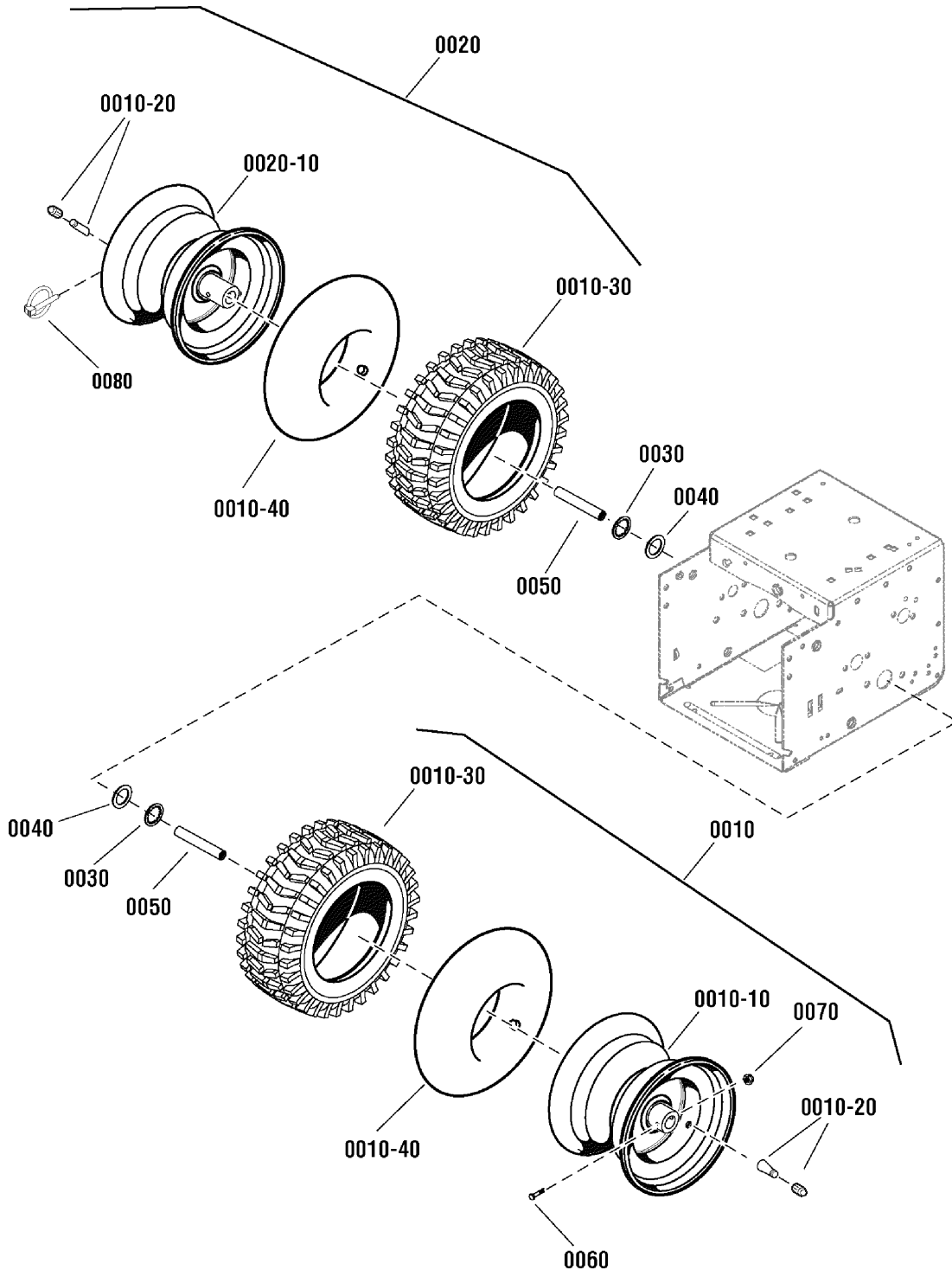

The above parts group applies to the following Mfg. Nos.:

1695952 - Champion 11.5TP 27" Dual Stage Snowthrower

1695953 - Champion 14.5TP 30" Dual Stage Snowthrower

Wheel & Tire Group

REF NO	PART NO.	QTY.	DESCRIPTION
0010	1751288YP	1	WHEEL & TIRE ASSEMBLY, LH (Includes Ref. Nos. 0010-10, 0010-20, 0010-30 & 0010-40)
0010-10	-----	1	* WHEEL, Rim, LH
0010-20	2172353SM	2	VALVE STEM & CAP
0010-30	1751298YP	2	TIRE, 4.80 - 8
0010-40	2164247SM	2	TUBE, Tire
0020	1751289YP	1	WHEEL & TIRE ASSEMBLY, RH (Includes Ref. Nos. 0020-10, 0010-20, 0010-30 & 0010-40)
0020-10	-----	1	* WHEEL, Rim, RH, 8 x 3.75
0030	1657528SM	2	RING, Retaining
0040	712120MA	2	WASHER, Flat, 3/4
0050	1501138MA	2	BUSHING, Wheel
0060	577015MA	1	CAPSCREW, Hex, 1/4-20 x 1-3/4, G5
0070	15X145MA	1	NUT, Hex Nylock, 1/4-20
0080	73842MA	1	PIN, Klik

Footnotes

* Not a servicable part. Order complete wheel and tire assembly.

The above parts group applies to the following Mfg. Nos.:

1695952 - Champion 11.5TP 27" Dual Stage Snowthrower

1695953 - Champion 14.5TP 30" Dual Stage Snowthrower

Decals Group

NOTE: Unless noted otherwise,
use the standard hardware torque
specification chart.

atalog_Data\MUR\Images\groups\2980000\2989381

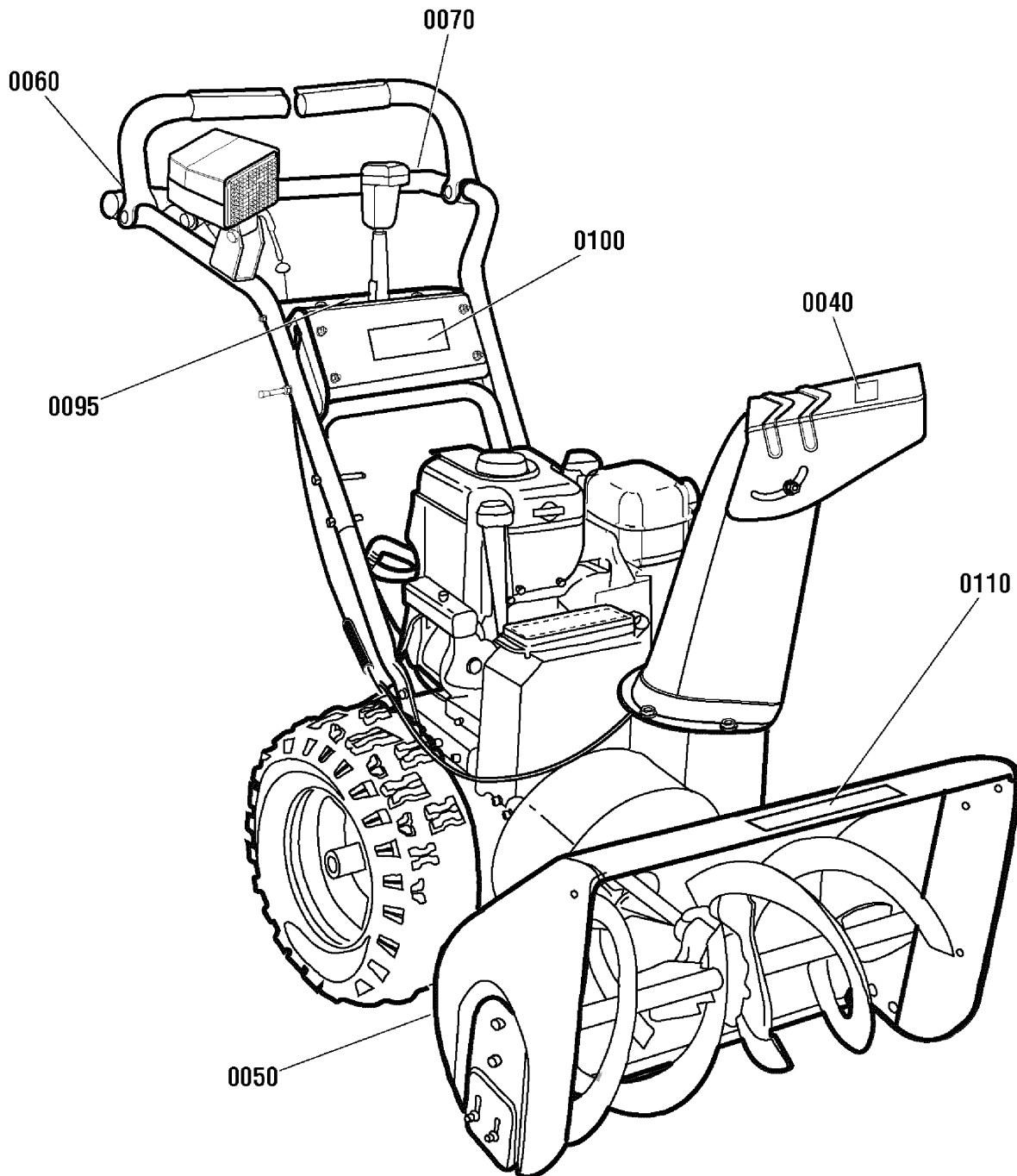

The above parts group applies to the following Mfg. Nos.:

1695952 - Champion 11.5TP 27" Dual Stage Snowthrower

1695953 - Champion 14.5TP 30" Dual Stage Snowthrower

Decals Group

REF NO	PART NO.	QTY.	DESCRIPTION
0040	1727207SM	1	DECAL, Chute Warning
0050	1737867YP	1	DECAL, Danger Auger Icons
0060	1737869YP	1	DECAL, Auger Control Symbols
0070	1737870YP	1	DECAL, Traction Control Symbols
0095	1737872YP	1	DECAL, 1-6 Transmission Speed Control
0100	1751199YP	1	DECAL, Logo, Dash
0110	1751125YP	1	DECAL, Auger, 27"
0110	1751202YP	1	DECAL, Auger, 30"
0060	680230ZMA	2	TOOL, Hex, 7/16 & 1/2 (Not Illustrated)

Footnotes

The above parts group applies to the following Mfg. Nos.:

1695952 - Champion 11.5TP 27" Dual Stage Snowthrower

1695953 - Champion 14.5TP 30" Dual Stage Snowthrower

Headlight Group

NOTE: Unless noted otherwise,
use the standard hardware torque
specification chart.

:alog_Data\MUR\Images\groups\2980000\2989377c

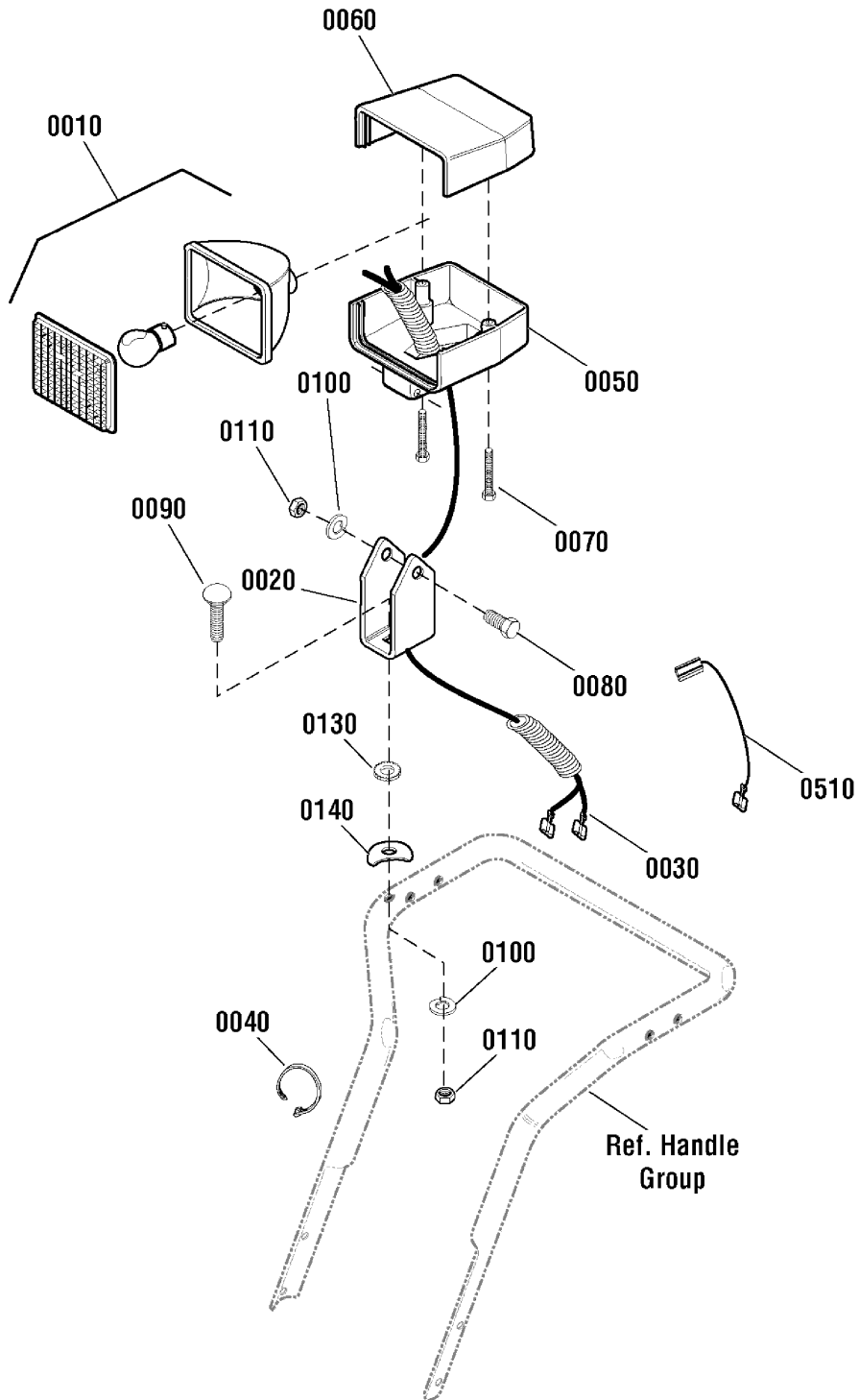

The above parts group applies to the following Mfg. Nos.:

1695952 - Champion 11.5TP 27" Dual Stage Snowthrower

1695953 - Champion 14.5TP 30" Dual Stage Snowthrower

Headlight Group

REF NO	PART NO.	QTY.	DESCRIPTION
0010	762343MA	1	LIGHT, Halogen
0020	4029YZMA	1	BRACKET, Light Handle
0030	1738347YP	1	HARNESS, Wiring (Use on 11.5TP Models)
0030	1501455MA	1	HARNESS, Wiring (Use on 14.5TP Models)
0040	032618MA	1	CABLE TIE
0050	1501514MA	1	CASE, Headlight, Lower
0060	583490MA	1	CASE, Headlight, Upper
0070	307781MA	2	SCREW, Phillips Head, Plastite, # 8-16 x 1-3/4
0080	235MA	1	CAPSCREW, Hex Head, 5/16-18 x 2
0090	002X88MA	1	BOLT, Carriage, 5/16-18 x 2
0100	71060MA	2	WASHER, Splitlock, 5/16
0110	15X144MA	2	NUT, Hex, 5/16-18
0130	71061MA	1	LOCKWASHER, External Tooth, 5/16
0140	580527MA	1	WASHER, 5/16
0510	1735255YP	1	PIGTAIL (Use on 14.5TP Models)

Footnotes

The above parts group applies to the following Mfg. Nos.:

1695952 - Champion 11.5TP 27" Dual Stage Snowthrower

1695953 - Champion 14.5TP 30" Dual Stage Snowthrower

Discharge Chute Group

NOTE: Unless noted otherwise,
use the standard hardware torque
specification chart.

atalog_Data\MUR\Images\groups\2980000\2989062

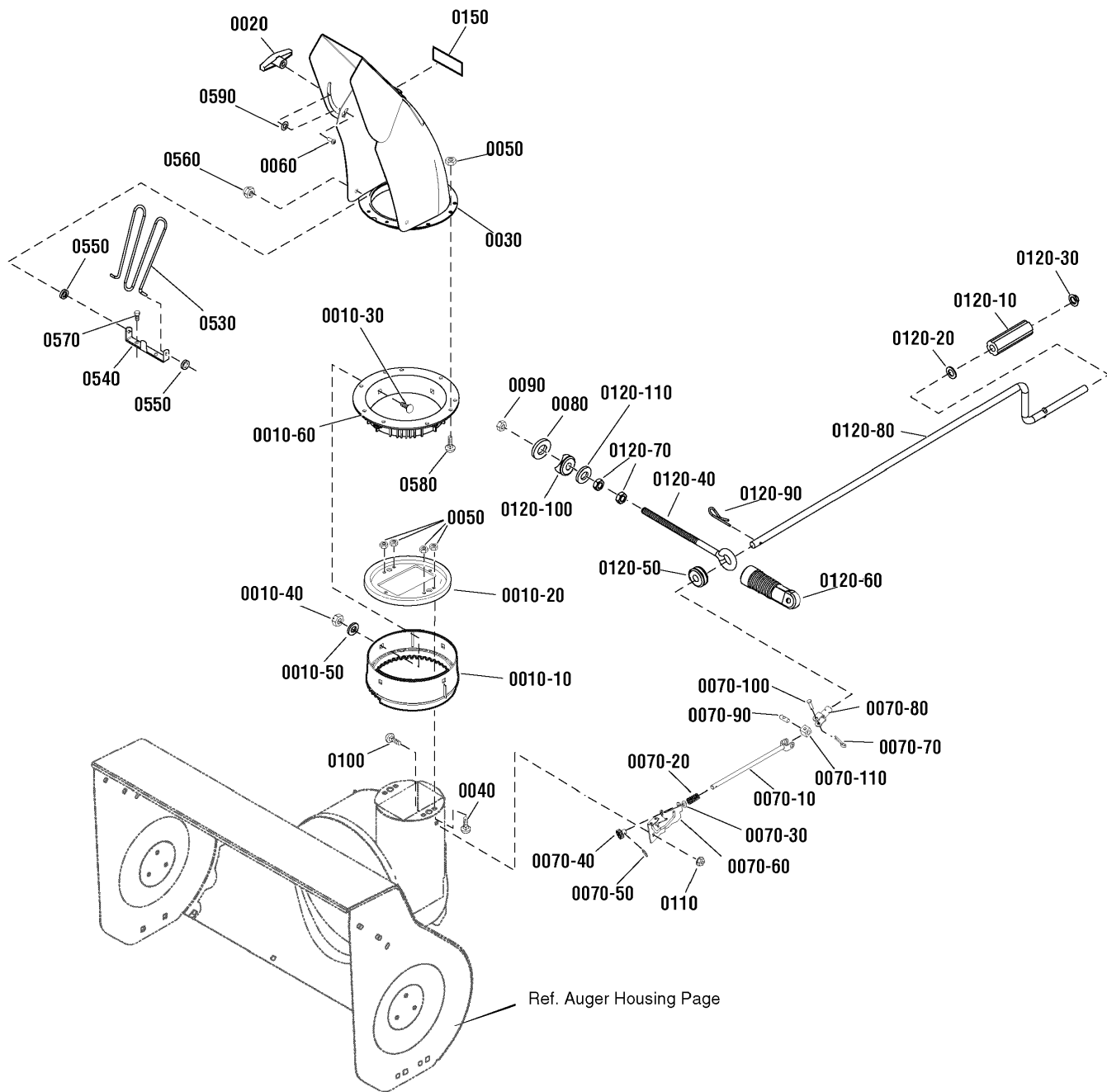

The above parts group applies to the following Mfg. Nos.:

- 1695952 - Champion 11.5TP 27" Dual Stage Snowthrower
- 1695953 - Champion 14.5TP 30" Dual Stage Snowthrower

Discharge Chute Group

REF NO	PART NO.	QTY.	DESCRIPTION
0010-10	1501282MA	1	RING, Outer Chute
0010-20	1501932YZMA	1	COLLAR, Chute
0010-30	2X100MA	4	BOLT, Carriage, 5/16-18 x 1
0010-40	71038MA	4	NUT, Hex Nylock, 5/16-18
0010-50	71071MA	4	WASHER, Flat, 3/8
0010-60	1741917YP	1	RING, Inner Chute
0020	1501260MA	1	KNOB, Wing, w/Nut, 5/16-18
0030	1736380AYP	1	CHUTE ASSEMBLY
0040	1935450SM	4	CAPSCREW, Hex Flange Head, 1/4-20 x 3/4, G5
0050	5025391SM	8	NUT, Nylock Flange, 1/4-20
0060	002X97MA	1	BOLT, Carriage, 5/16-18 x 1-1/2
--	1501534MA	1	GEAR & YOKE ROD ASSEMBLY (Includes Ref. Nos. 0070-10, 0070-20, 0070-30, 0070-40, 0070-50, 0070-60, 0070-70, 0070-80, 0070-90, 0070-100 & 0070-110)
0070-10	1501533YZMA	1	ROD, Yoke Crank
0070-20	164X37MA	1	SPRING, Compression
0070-30	017X48MA	1	WASHER, Flat, 3/8
0070-40	1501067MA	1	GEAR, 9 Tooth
0070-50	1501293MA	1	PIN, Hair
0070-60	1740591AYP	1	BRACKET, Chute Gear
0070-70	579493MA	1	PIN, Cotter
0070-80	1501075YZMA	1	YOKE TUBE ASSEMBLY
0070-90	578060MA	1	PIN, Universal Joint
0070-100	578309MA	1	PIN, Clevis
0070-110	578063MA	1	BLOCK, Universal Pivot
0080	71072MA	1	WASHER, Flat, 7/16
0090	71046MA	1	NUT, Nylock, 3/8-16
0100	02X101MA	1	BOLT, Carriage, 1/4-20 x 3/4
0110	15X145MA	1	NUT, Hex Nylock, 1/4-20
--	1740589MA	1	ROD ASSEMBLY (Includes Ref. Nos. 0120-10, 120-20, 0120-30, 0120-40, 0120-50, 0120-60, 0120-70, 0120-80, 0120-90, 0120-100 & 0120-110)
0120-10	307399MA	1	GRIP, Chute
0120-20	309312MA	1	WASHER, Flat, 7/16
0120-30	73664MA	1	PUSHNUT, 3/8
0120-40	1501456MA	1	EYEBOLT, 3/8-16 x 6-1/2
0120-50	148MA	1	GROMMET, Eyebolt
0120-60	1501457MA	1	BOOT, Eyebolt
0120-70	71045MA	2	NUT, Hex Jam, 3/8-16
0120-80	1501074YZMA	1	CRANK, Chute Turn
0120-90	0031X6MA	1	PIN, Hair 3/8 x 1-5/8
0120-100	309344MA	2	ADAPTOR, Boot to Handle
0120-110	71072MA	1	WASHER, Flat, 7/16

Footnotes

The above parts group applies to the following Mfg. Nos.:

1695952 - Champion 11.5TP 27" Dual Stage Snowthrower
 1695953 - Champion 14.5TP 30" Dual Stage Snowthrower

Discharge Chute Group

NOTE: Unless noted otherwise, use the standard hardware torque specification chart.

atalog_Data\MUR\Images\groups\2980000\2989062

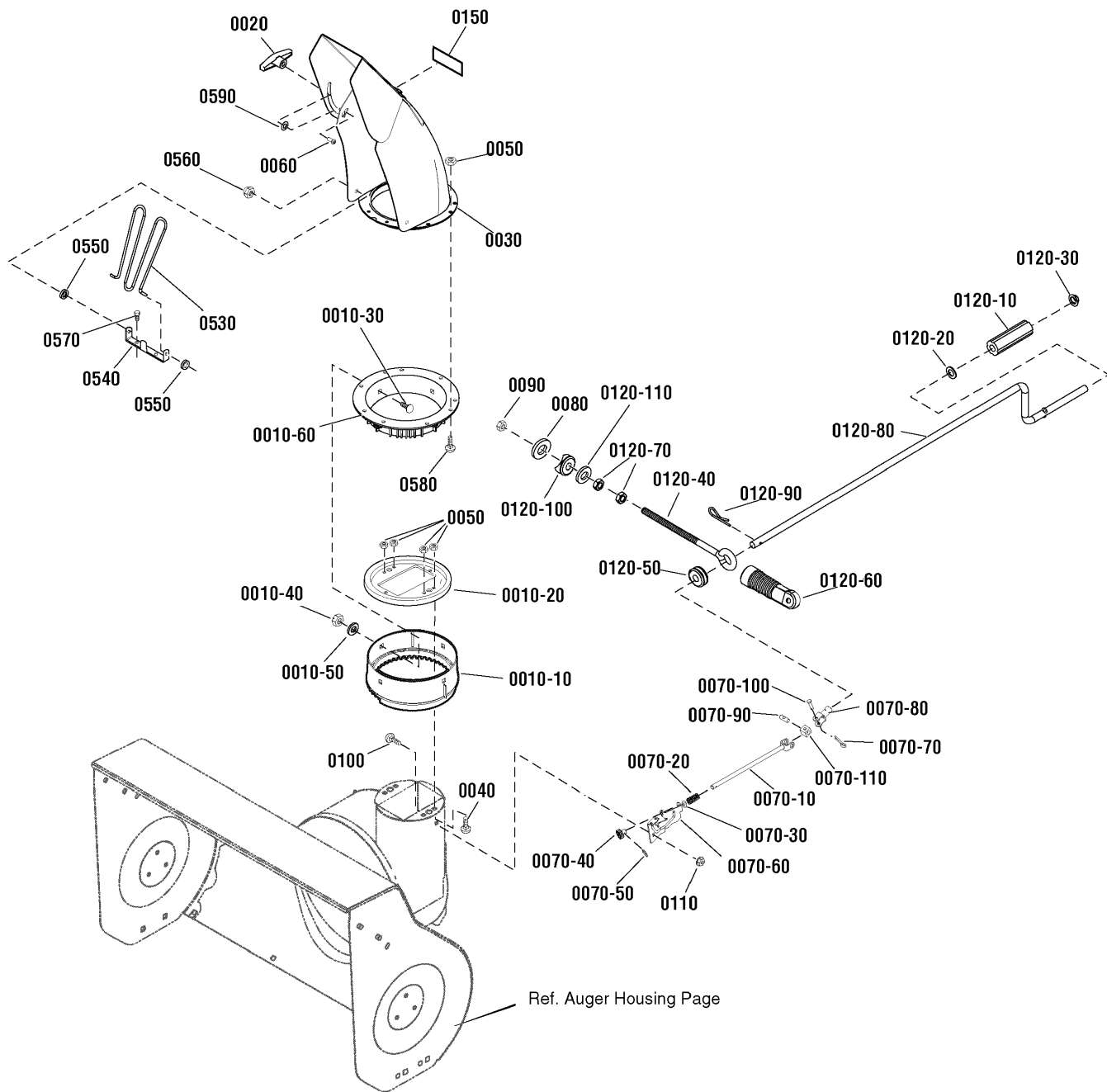

The above parts group applies to the following Mfg. Nos.:

- 1695952 - Champion 11.5TP 27" Dual Stage Snowthrower
- 1695953 - Champion 14.5TP 30" Dual Stage Snowthrower

Discharge Chute Group

REF NO	PART NO.	QTY.	DESCRIPTION
0150	1733601	2	DECAL, Hinge
0530	1733475SM	1	GUARD, Chute
0540	1737683YP	1	BRACKET, Chute Guard
0550	1738174YP	2	GROMMET, Chute Guard
0560	1960140SM	2	PUSHNUT, 3/16
0570	1925003SM	2	CAPSCREW, Hex Washer Head, Taptite, 1/4-20 x 1/2
0580	7091530SM	4	BOLT, Carriage, 1/4-20 x 3/4, G5
0590	2860210SM	2	WASHER, Nylon, 3/8

Footnotes

The above parts group applies to the following Mfg. Nos.:

1695952 - Champion 11.5TP 27" Dual Stage Snowthrower

1695953 - Champion 14.5TP 30" Dual Stage Snowthrower

Gear Case Assembly

NOTE: Unless noted otherwise,
use the standard hardware torque
specification chart.

atalog_Data\MUR\Images\groups\1730000\1736803

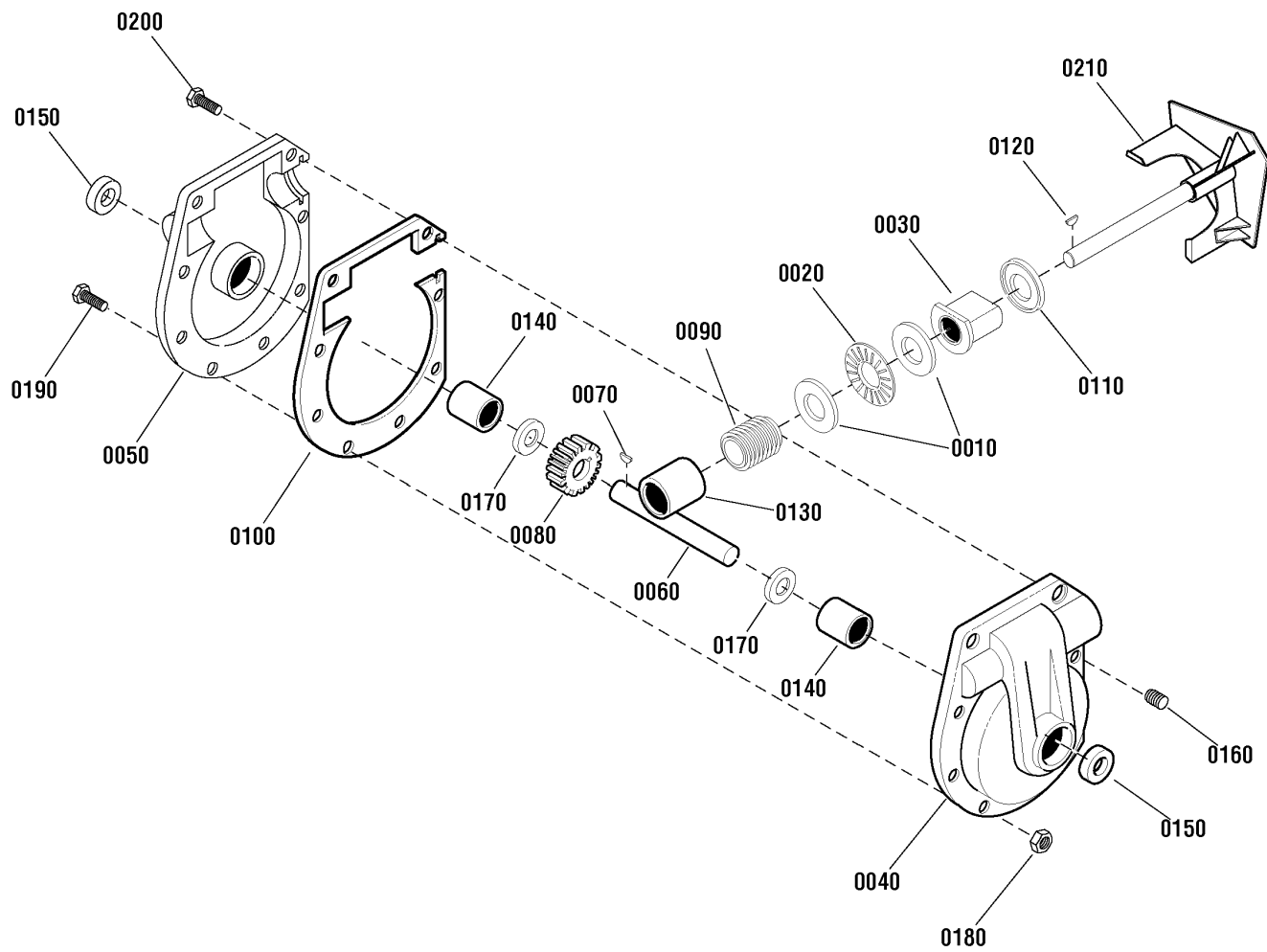

The above parts group applies to the following Mfg. Nos.:

- 1695952 - Champion 11.5TP 27" Dual Stage Snowthrower
- 1695953 - Champion 14.5TP 30" Dual Stage Snowthrower

Gear Case Assembly

REF NO	PART NO.	QTY.	DESCRIPTION
0010	48275MA	2	WASHER, Thrust
0020	50684MA	1	BEARING, Roll
0030	583126MA	1	BEARING, Flange
0040	895MA	1	GEAR CASE, Left
0050	896MA	1	GEAR CASE, Right
0060	760529MA	1	SHAFT, Auger Out, 27 (Use on 27" Models)
0060	760527MA	1	SHAFT, Auger Out, 30 (Use on 30" Models)
0070	73905MA	1	KEY, Woodruf
0080	53730MA	1	GEAR, Worm
0090	53732MA	1	WORMGEAR
0100	897MA	1	GASKET, Gear Box
0110	53737MA	1	RING, Quad
0120	50795MA	1	KEY, Hi-Pro
0130	53731MA	1	BEARING, Sleeve
0140	53743MA	2	BEARING, Sleeve
0150	780151MA	2	SEAL, Oil
0160	53749MA	1	PLUG, Pipe
0170	53748MA	2	WASHER, Flat, 1
0180	71100MA	8	NUT, Hex Flange, Serrated, 5/16-24
0190	910828MA	7	BOLT, Hex 5/16-24 x 1
0200	330434MA	1	SCREW, Hex Head, 5/16-24 x 1-1/2
0210	1740584AYP	1	IMPELLER

Footnotes

The above parts group applies to the following Mfg. Nos.:

1695952 - Champion 11.5TP 27" Dual Stage Snowthrower
1695953 - Champion 14.5TP 30" Dual Stage Snowthrower

Controls Group

NOTE: Unless noted otherwise,
use the standard hardware torque
specification chart.

:\alog_Data\MUR\Images\groups\2980000\2989377b

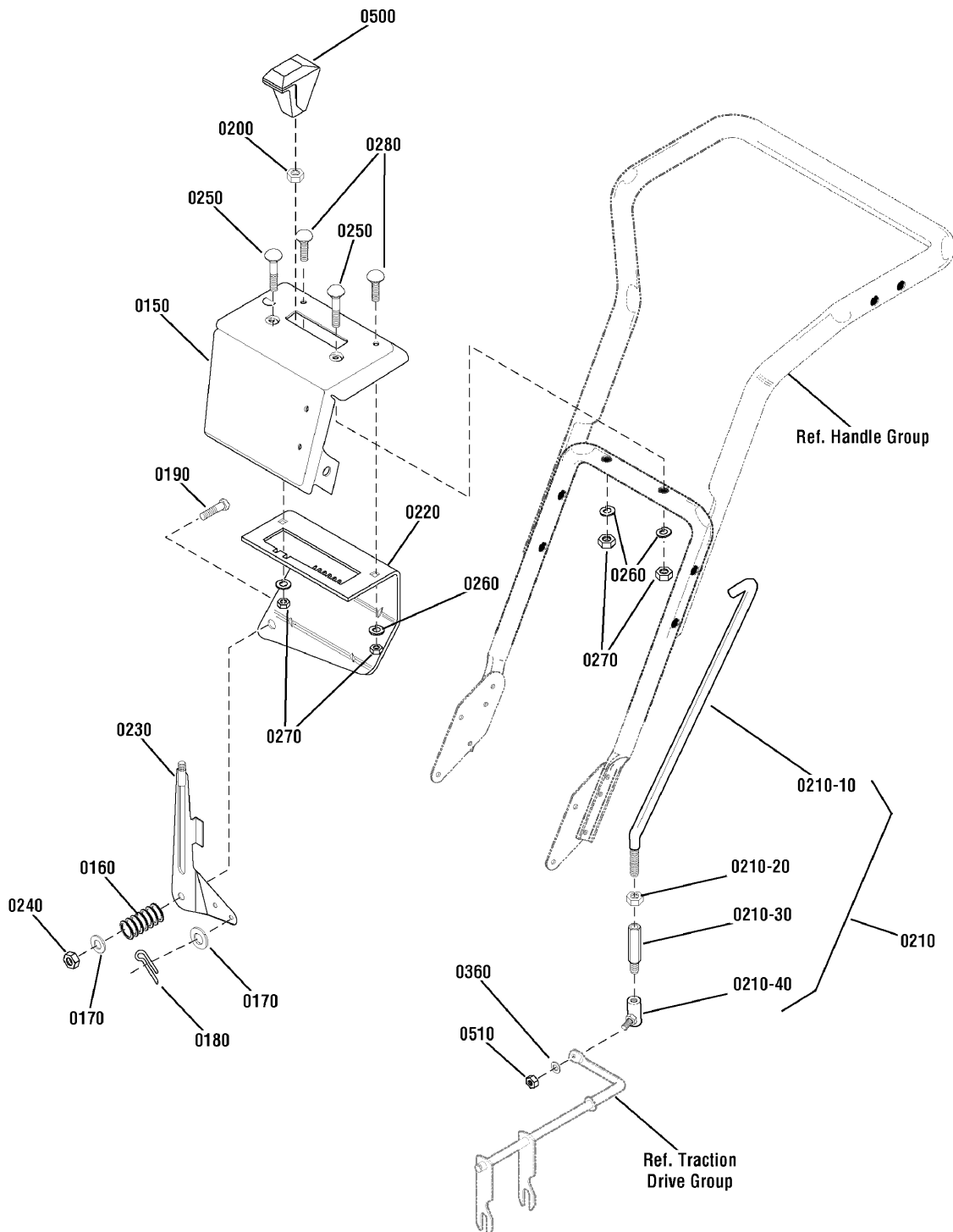

The above parts group applies to the following Mfg. Nos.:

1695952 - Champion 11.5TP 27" Dual Stage Snowthrower

1695953 - Champion 14.5TP 30" Dual Stage Snowthrower

Controls Group

REF NO	PART NO.	QTY.	DESCRIPTION
0150	1741123ZYP	1	PANEL, Control
0160	50786MA	1	SPRING, 3/4
0170	71071MA	2	WASHER, Flat
0180	71081MA	1	PIN, Cotter
0190	302900MA	1	CAPSCREW, Hex Head, 5/16-18 x 1-3/4
0200	71045MA	1	NUT, Hex Jam, 3/8-16
0210	1741110MA	1	ROD ASSEMBLY, Speed (Includes Ref. Nos. 0210-10, 0210-20, 0210-30 & 0210-40)
0210-10	1502019MA	1	ROD, Speed
0210-20	71042MA	1	NUT, Hex, 5/16-24
0210-30	6352MA	1	ADAPTOR, Rod Speed
0210-40	50782MA	1	BALLJOINT
0220	1741119AYP	1	BRACKET, Shift Control
0230	1741118AYP	1	LEVER ASSEMBLY, Shift
0240	71038MA	1	NUT, Hex Nylock, 5/16-18
0250	1931323SM	2	BOLT, Carriage, Short Neck, 1/4-20 x 2, G5
0260	71059MA	4	WASHER
0270	71034MA	4	NUT, Hex, 1/4-20
0280	3809MA	2	BOLT, Carriage, 1/4-20 x 5/8
0360	71060MA	1	WASHER, Splitlock, 5/16
0500	304437MA	1	GRIP, Lever
0510	71042MA	1	NUT, Hex, 5/16-24

Footnotes

The above parts group applies to the following Mfg. Nos.:

1695952 - Champion 11.5TP 27" Dual Stage Snowthrower

1695953 - Champion 14.5TP 30" Dual Stage Snowthrower

Hardware Identification & Torque Specifications

Torque Specification Chart								
FOR STANDARD METRIC MACHINE HARDWARE (Tolerance ± 20%)								
Property Class	5.6		8.8		10.9		12.9	
	Class 5.6		Class 8.8		Class 10.9		Class 12.9	
Size Of Hardware	in/lbs		in/lbs		in/lbs		in/lbs	
	ft/lbs	Nm.	ft/lbs	Nm.	ft/lbs	Nm.	ft/lbs	Nm.
M3	5.88	.56	13.44	1.28	19.2	1.80	22.92	2.15
M4	13.44	1.28	30.72	2.90	43.44	4.10	52.56	4.95
M5	26.4	2.50	60.96	5.75	5.97	8.10	7.15	9.7
M6	44.64	4.3	7.3	9.9	10.3	14	12.1	16.5
M7	5.2	7.1	12.1	16.5	16.9	23	19.9	27
M8	7.7	10.5	17.7	24	25	34	29	40
M10	15	21	35	48	50	67	59	81
M12	26	36	61	83	86.2	117	103	140
M14	42	58	101	132	136	185	162	220
M16	64	88	147	200	210	285	250	340
M18	89	121	202	275	287	390	346	470
M20	126	171	290	390	405	550	486	660
M22	169	230	390	530	559	745	656	890
M24	217	295	497	375	708	960	840	1140
M27	320	435	733	995	1032	1400	1239	1680
M30	435	590	995	1350	1401	1900	1681	2280
M33	590	800	1349	1830	1902	2580	2278	3090
M36	759	1030	1740	2360	2441	3310	2935	3980
M39	988	1340	2249	3050	3163	4290	3798	5150

The guides and ruler furnished below are designed to help you select the appropriate hardware.

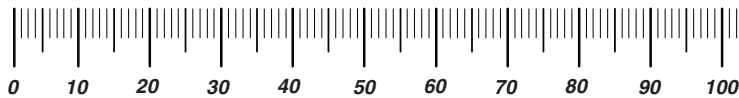

Nut, M8

Thread Diameter (mm)
Inside Diameter (in)
Threads per inch

Nut, 1/2-16

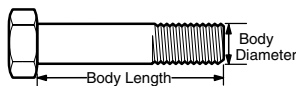

Screw, M8- 1.25 x 25

Thread Diameter (mm)
Body Diameter
Distance between threads (mm)
Threads per inch
Body Length (mm)
Body Length (in)

Screw, 1/2- 16 x 2

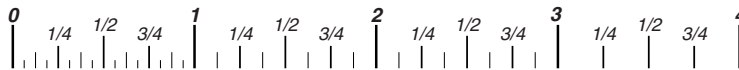

Standard Hardware Sizing

When a washer or nut is identified as **1/2"** (M8), this is the *Nominal size*, meaning the *inside diameter* is 1/2 inch (8mm metric thread diameter); if a second number is present it represents the *threads per inch* (distance between threads).

When bolt or capscrew is identified as **1/2 - 16 x 2"** (M8 - 1.25 x 50), this means the *Nominal size*, or body diameter is 1/2 inch (8mm metric thread diameter), the second number, 16, represents the *threads per inch*, (*1.25 thread diameter*). The final number is the body length of the bolt or screw, 2 inches (50mm).

Torque Specification Chart						
FOR STANDARD MACHINE HARDWARE (Tolerance ± 20%)						
Hardware Grade	No Marks		No Marks		No Marks	
	SAE Grade 2		SAE Grade 5		SAE Grade 8	
Size Of Hardware	in/lbs		in/lbs		in/lbs	
	ft/lbs	Nm.	ft/lbs	Nm.	ft/lbs	Nm.
8-32	19	2.1	30	3.4	41	4.6
8-36	20	2.3	31	3.5	43	4.9
10-24	27	3.1	43	4.9	60	6.8
10-32	31	3.5	49	5.5	68	7.7
1/4-20	66	7.6	8	10.9	12	16.3
1/4-28	76	8.6	10	13.6	14	19.0
5/16-18	11	15.0	17	23.1	25	34.0
5/16-24	12	16.3	19	25.8	29	34.0
3/8-16	20	27.2	30	40.8	45	61.2
3/8-24	23	31.3	35	47.6	50	68.0
7/16-14	30	40.8	50	68.0	70	95.2
7/16-20	35	47.6	55	74.8	80	108.8
1/2-13	50	68.0	75	102.0	110	149.6
1/2-20	55	74.8	90	122.4	120	163.2
9/16-12	65	88.4	110	149.6	150	204.0
9/16-18	75	102.0	120	163.2	170	231.2
5/8-11	90	122.4	150	204.0	220	299.2
5/8-18	100	136	180	244.8	240	326.4
3/4-10	160	217.6	260	353.6	386	525.0
3/4-16	180	244.8	300	408.0	420	571.2
7/8-9	140	190.4	400	544.0	600	816.0
7/8-14	155	210.8	440	598.4	660	897.6
1-8	220	299.2	580	788.8	900	1,244.0
1-12	240	326.4	640	870.4	1,000	1,360.0

NOTES

- These torque values are to be used for all hardware excluding: locknuts, self-tapping screws, thread forming screws, sheet metal screws and socket head setscrews.
- Recommended seating torque values for locknuts:
 - for prevailing torque locknuts - use 65% of grade 5 torques.
 - for flange whizlock nuts and screws - use 135% of grade 5 torques.
- Unless otherwise noted on assembly drawings, all torque values must meet this specification.

Common Hardware Types

Hex Head Capscrew



Washer



Lockwasher

Carriage Bolt



Hex Nut

Wrench & Fastener Size Guide

1/4" Bolt or Nut Wrench—7/16"	5/16" Bolt or Nut Wrench—1/2"	3/8" Bolt or Nut Wrench—9/16"	7/16" Bolt or Nut Wrench (Bolt)—5/8" Wrench (Nut)—11/16"	1/2" Bolt or Nut Wrench—3/4"
M6 Bolt or Nut Wrench—10mm	M8 Bolt or Nut Wrench—13mm	M10 Bolt or Nut Wrench—17mm	M12 Bolt or Nut Wrench—19mm	M14 Bolt or Nut Wrench—22mm

CHAMPION

**IT IS THE POLICY OF BRIGGS & STRATTON CORP. TO IMPROVE ITS PRODUCTS
WHENEVER IT IS POSSIBLE AND PRACTICAL TO DO SO. WE RESERVE THE RIGHT TO
MAKE CHANGES OR ADD IMPROVEMENTS AT ANY TIME WITHOUT INCURRING ANY
OBLIGATION TO MAKE SUCH CHANGES ON PRODUCTS.**

Briggs & Stratton Yard Power Products Group

3515 N. 124 Street / PO Box 702
Wauwatosa, WI 53222 USA

www.murray.com

© Copyright 2010 by Briggs & Stratton Corporation
Milwaukee, WI, USA. All rights reserved