

GHP40-2水泵机组配置表

GHP40-2

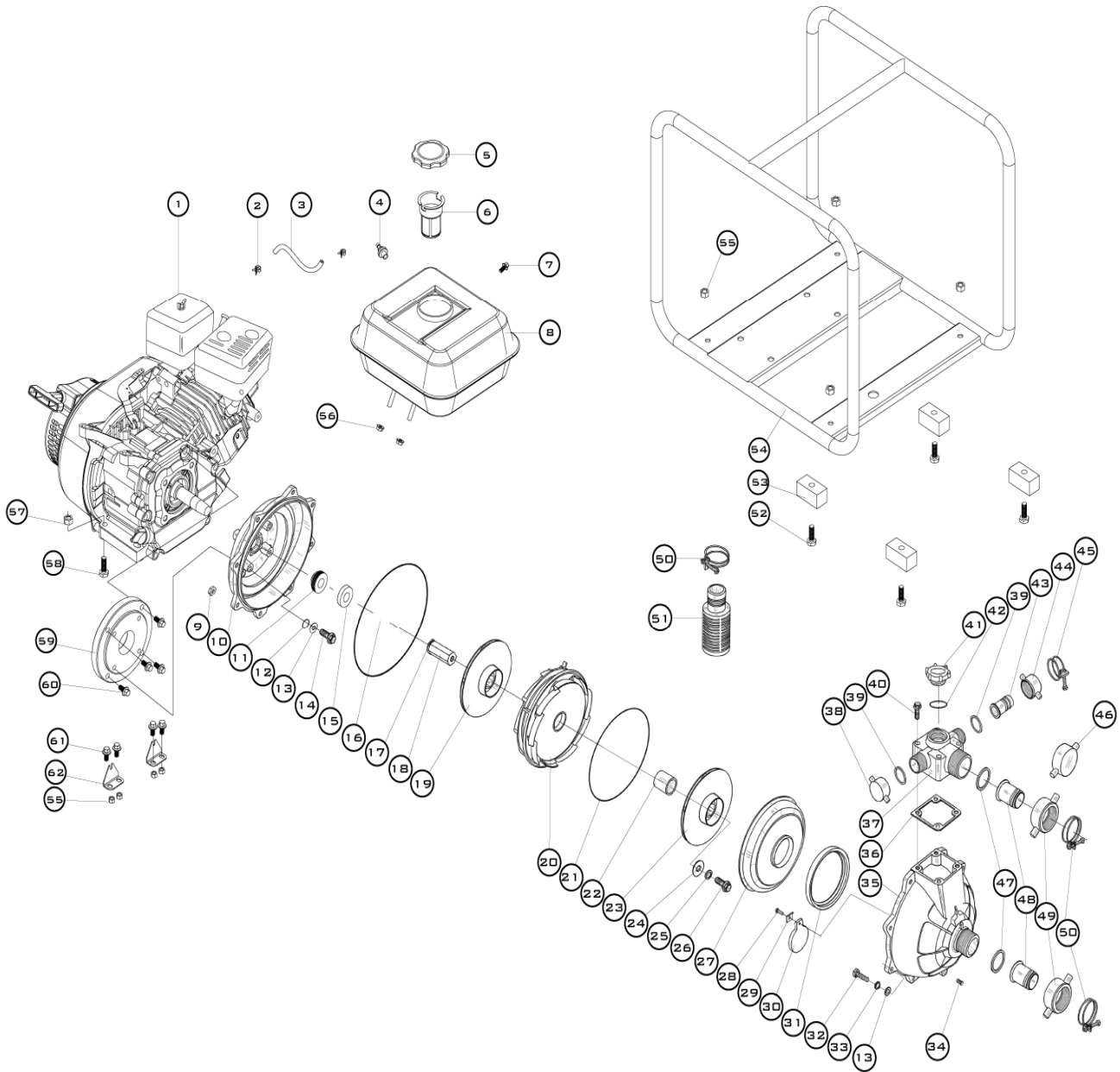

NO.	CODE	DESCRIPTION	QTY.
1	2EP270	UP177 gasoline engine	1
2	3A2006001	Pipe clamp	2
3	3B0111007	Fuel pipe	1
4	3A2006400	Connector	1
5	3A2006100	Fuel tank cup	1
6	3A2006007	Filter cup	1
7	3S22060251	flange bolt M6X25	1
8	3A3006009	Fuel tank	1
9	3S11081	nut M8	8
10	3G4040040	Pump cover	1
11	3G4040048	Mechanical seal	1
12	3G4050004	O ring $\phi 12 \times \phi 7 \times \phi 2.4$	4
13	3S31082	flat washer $\phi 8$	12
14	3S21080451	bolt M8X45	4

GHP40-2水泵机组配置表

15	3G4040047	porcelain seal	1
16	3G4040039	O ring	1
17	3G4040037	block ring	1
18	3G4040036	shaft	1
19	3G4040033	volute casing	1
20	3G4040031	impeller discreteness	1
21	3G4040034	O ring	1
22	3G4040032	sleeve	1
23	3G4040035	volute casing	1
24	3S3610126	gasket $\phi 10$	1
25	3G4040029	gasket $\phi 10$	1
26	3S21100161	bolt M10X16	1
27	3G4040026	volute basing cover	1
28	3S27050162	bolt	1
29	3G4040015	inpact block	1
30	3G4040024	check discreteness	1
31	3G4040027	volute casing plastic seal gasket	1
32	3S22080351	flange bolt M8X35	8
33	3G4040021	gasket $\phi 8$	8
34	3G4040023	square screw cap	1
35	3G4040014	pump body	1
36	3G4040011	seal gasket	1
37	3G4040004	outlet bracket	1
38	3G4040005	outlet cover II	2
39	3G4040008	seal gasket II	2
40	3S22080601	flange bolt M8X60	4
41	3G4040002	water input cover	1
42	3G4040003	O-ring	1
43	3G4040006	hose connector II	2
44	3G4040007	hose ringer II	2
45	3G4040042	hose clamp II	2
46	3G4040009	outlet cover II	2
47	3G4040010	seal gasket I	2
48	3G4040012	hose connector I	2
49	3G4040013	hose ringer I	2
50	3G4040041	hose clamp I	3
51	3G4040043	filter net	1
52	3S22080201	flange bolt M8X20	4
53	3G20011	shock absorber	4
54	3JGH4020001	frame	1
55	3S12081	flange nut M8	8
56	3S12061	flange nut M6	2
57	3S11101	nut M10	4
58	3S21100401	bolt M10X40	4
59	3G20010	240F high pressure washer flange	1
60	3S22080351	flange bolt M8X35	4
61	3S22080121	flange bolt M8X12	4
62	3G20033	390 pump prop	2

GHP40-2水泵机组配置表

|

GHP40-2水泵机组配置表

GHP40-2水泵机组配置表

GHP40-2水泵机组配置表